

***martin***®

***Martin***® ***QC1+***™  
***Cleaner HD***

[Go to Martin® QC1+™ Cleaner HD web page](#)

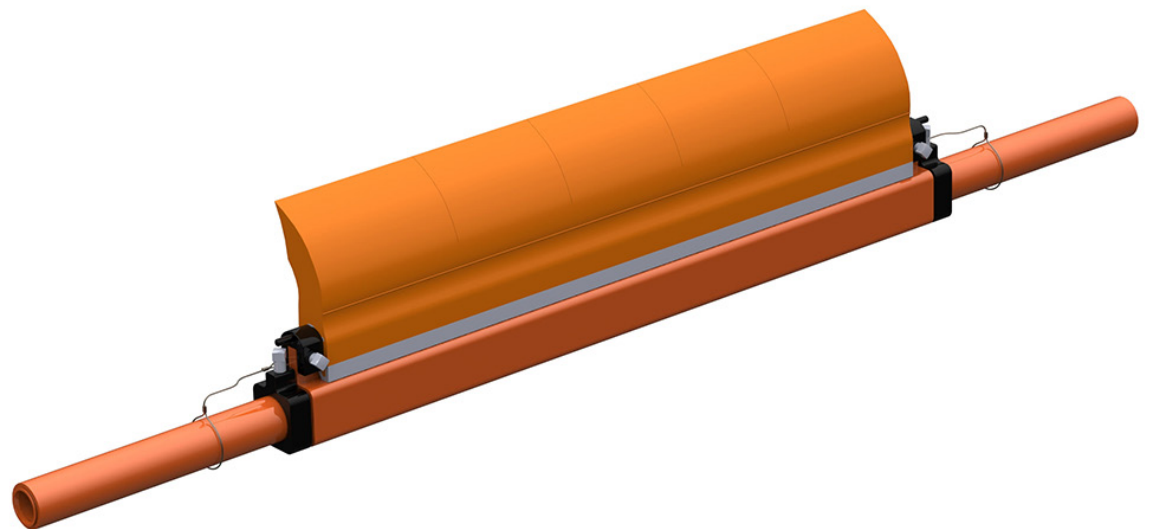

***Operator's Manual***  
***M4124***

# Important

MARTIN ENGINEERING HEREBY DISCLAIMS ANY LIABILITY FOR: DAMAGE DUE TO CONTAMINATION OF THE MATERIAL; USER'S FAILURE TO INSPECT, MAINTAIN AND TAKE REASONABLE CARE OF THE EQUIPMENT; INJURIES OR DAMAGE RESULTING FROM USE OR APPLICATION OF THIS PRODUCT CONTRARY TO INSTRUCTIONS AND SPECIFICATIONS CONTAINED HEREIN. MARTIN ENGINEERING'S LIABILITY SHALL BE LIMITED TO REPAIR OR REPLACEMENT OF EQUIPMENT SHOWN TO BE DEFECTIVE.

Observe all safety rules given herein along with owner and Government standards and regulations. Know and understand lockout/tagout procedures as defined by American National Standards Institute (ANSI) z244.1-1982, *American National Standard for Personnel Protection - Lockout/Tagout of Energy Sources - Minimum Safety Requirements* and Occupational Safety and Health Administration (OSHA) Federal Register, Part IV, 29 CFR Part 1910, *Control of Hazardous Energy Source (Lockout/Tagout); Final Rule*.

The following symbols may be used in this manual:



**Danger:** Immediate hazards that will result in severe personal injury or death.



**Warning:** Hazards or unsafe practices that could result in personal injury.



**Caution:** Hazards or unsafe practices that could result in product or property damages.



**Important:** Instructions that must be followed to ensure proper installation/operation of equipment.



**Note:** General statements to assist the reader.

# Table of Contents

---

<b>Section</b>	<b>Page</b>
List of Figures . . . . .	ii
List of Tables . . . . .	ii
Introduction . . . . .	1
General . . . . .	1
Installations without chutework . . . . .	1
Belt cleaner inspection access . . . . .	1
Belt cleaner blades . . . . .	1
References . . . . .	1
Materials required . . . . .	1
Urethane shelf life . . . . .	2
Safety . . . . .	3
Before Installing Belt Cleaner . . . . .	4
Installing Belt Cleaner and Tensioner . . . . .	7
Locating belt cleaner mainframe . . . . .	7
Removing blade . . . . .	8
Installing tensioner . . . . .	8
Installing blade . . . . .	8
After Installing Belt Cleaner . . . . .	9
Weekly Maintenance . . . . .	10
Troubleshooting . . . . .	11
Part Numbers . . . . .	12

## List of Figures

---

Figure	Title	Page
1	Belt Cleaner Mounting Locations . . . . .	5
2	Belt Cleaner Mainframe Location & Chute Wall Cutouts. . . . .	7
3	Removing and Installing Blade . . . . .	8
4	Martin® QC1+™ Cleaner HD Assembly, P/N C1QCHSXXSXXXPX . . . . .	13
5	Martin® Conveyor Products Warning Label, P/N 23395 . . . . .	16

## List of Tables

---

Table	Title	Page
I	Martin® QC1+™ Cleaner HD Blade Colors, Materials and Specifications . . . . .	2
II	Urethane Shelf Life . . . . .	2
III	Part Numbers and Dimensions for Martin® QC1+™ Cleaner HD Assembly . . . . .	14

## **General**

The Martin® QC1+™ Cleaner HD combines effective removal of carryback with “quick-change” replacement of a long-lasting, one-piece blade. To introduce product back into the product flow, the Martin® QC1+™ Cleaner HD is installed on the face of the head pulley. On a dual-cleaner system, a Secondary Cleaner is installed immediately following the Pre-Cleaner to remove stubborn material left on the conveyor belt. If a Pre-Cleaner cannot be used because of space limitations, Secondary Cleaners can be installed alone. Multiple Pre-Cleaners and/or Secondary Cleaners may be required to clean the belt. If the material-handling process or product could be affected by contamination from the use of these belt cleaners, the user is responsible for taking the necessary steps to prevent contamination. Consult Martin Engineering or a representative for alternate belt cleaners or belt cleaner locations to use where contamination may be an issue.

## **Installations without chutework**

These procedures were written for equipment that is being installed on enclosed pulley chutework. If the pulley is not enclosed, the equipment should be installed using the best available field resources and methods to ensure that the critical dimensions are followed for proper installation.

## **Belt cleaner inspection access**

If the belt cleaner is installed on enclosed pulley chutework, at least one Martin® Inspection Door should be installed. Martin® Inspection Doors are available from Martin Engineering or a representative.

## **Belt cleaner blades**

Martin® QC1+™ Cleaner HD Blades are available in five different materials (see Table I for specifications). Only standard (orange) Martin® QC1+™ Cleaner HD Blades are made of materials that meet Mine Safety and Health Administration (MSHA) requirements under “Interim Fire and Toxicity Criteria for Products Taken Into Underground Mines,” March 22, 1977 (MSHA acceptance number MSHA-IC-95/1, MSHA-IC-95/7).

## **References**

The following documents are referenced in this manual:

- American National Standards Institute (ANSI) z244.1-1982, *American National Standard for Personnel Protection - Lockout/Tagout of Energy Sources - Minimum Safety Requirements*, American National Standards Institute, Inc., 1430 Broadway, New York, NY 10018.
- Federal Register, Volume 54, Number 169, Part IV, 29 CFR Part 1910, *Control of Hazardous Energy Source (Lockout/Tagout); Final Rule*, Department of Labor, Occupational Safety and Health Administration (OSHA), 32nd Floor, Room 3244, 230 South Dearborn Street, Chicago, IL 60604.
- *Martin® Inspection Door Operator’s Manual*, P/N M3891
- *Martin® Twist Tensioner Operator Manual*, P/N M3837
- *Martin® Spring and Air Tensioners Operator Manual*, P/N M3263

## **Materials required**

Installation of this equipment requires the use of standard hand tools, grinder, welder, and cutting torch.

Table I. Martin® QC1+™ Cleaner HD Blade Colors, Materials and Specifications

URETHANE SELECTION	APPLICATION DESCRIPTION	TYPICAL MATERIALS	CONTINUOUS TEMPERATURE
Orange	<b>Standard Martin® Urethane</b> Suitable for 80% or more of all belt cleaner applications, including abrasive conditions.	Bauxite, Coke, Coal, Overburden Refuse	-20° to 160°F (-29° to 71°C)
Brown (BR)	<b>Chemical-Resistant Urethane</b> Improves resistance to chemicals; reduced absorption of water in high-moisture environments.	Limestone	-40° to 160°F (-40° to 71°C)
Green (GR)	<b>High-Temperature Urethane</b> For exposure to intermittent temperatures up to 350°F (177°C).	Clinker	-40° to 300°F (-40° to 149°C)
Clear (CL)	<b>Low-Rigidity Urethane</b> For dry products such as sand and gravel.	Gravel, Dry Sand	-20° to 160°F (-29° to 71°C)
Navy Blue (NB)	<b>Low-Adhesion Urethane</b> For sticky or tacky materials.	Cement, Glass, Wood Chips	-20° to 160°F (-29° to 71°C)

**IMPORTANT***Urethane shelf life*

Urethane put in service after exceeding its shelf life may wear differently and deteriorate quicker than normal urethane.

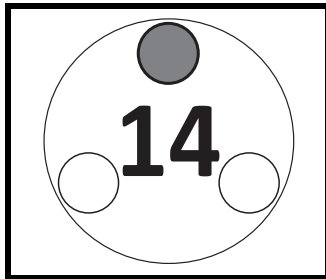
**NOTE**

Code Date is written near bottom of blade as mm/dd/yy-x. In addition to or in place of this date, you may see an imprinted date medallion similar to the example shown. In this example, “14” stands for the year 2014. The small circles represent the quarter of the year. If three circles are “punched” the blade was produced in the first quarter. If none of the circles are “punched” the blade was produced in the fourth quarter. If code date on your blade(s) is not legible or is missing, contact Martin Engineering or a representative.

Table II. Urethane Shelf Life

Blade Color	Shelf Life
Blue	1 Year from Code Date
Brown	2 Years from Code Date
Clear	1 Year from Code Date
Green	2 Years from Code Date
Orange	1 Year from Code Date

## Safety

All safety rules defined in the above documents and all owner/employer safety rules must be strictly followed when working on the belt cleaner.



### **⚠ DANGER**

Do not touch or go near the conveyor belt or conveyor accessories when the belt is running. Your body or clothing can get caught and you can be pulled into the conveyor, resulting in severe injury or death.



### **⚠ DANGER**

Before installing, servicing, or adjusting the belt cleaner, turn off and lockout / tagout / blockout / testout all energy sources to the conveyor and conveyor accessories according to ANSI standards. Failure to do so could result in serious injury or death.

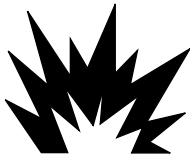

### **⚠ DANGER**

If this equipment will be installed in an enclosed area, test the gas level or dust content before using a cutting torch or welding. Using a torch or welding in an area with gas or dust may cause an explosion resulting in serious injury or death. Follow local confined space procedures.



### **⚠ WARNING**

Before using a cutting torch or welding the chute wall, cover the conveyor belt with a fire retardant cover. Failure to do so can allow the belt to catch fire. Follow local fire watch procedures.

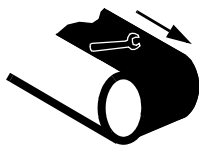

### **⚠ WARNING**

Remove all tools from the installation area and conveyor belt before turning on the conveyor. Failure to do so can cause serious injury to personnel or damage to the belt and conveyor.



### **⚠ WARNING**

Mainframe with blade can be heavy and may require two people to lift. Attempting to lift the belt cleaner without assistance could result in injury.

## Before Installing Belt Cleaner

### IMPORTANT

The delivery service is responsible for damage occurring in transit. Martin Engineering CANNOT enter claims for damages. Contact your transportation agent for more information.

1. Inspect shipping container for damage. Report damage to delivery service immediately and fill out delivery service's claim form. Keep any damaged goods subject to examination.
2. Remove belt cleaner assembly from shipping container.
3. If anything is missing contact Martin Engineering or a representative.



### ⚠ DANGER

Before installing, servicing, or adjusting the belt cleaner, turn off and lockout / tagout / blockout / testout all energy sources to the conveyor and conveyor accessories according to ANSI standards. Failure to do so could result in serious injury or death.

4. Turn off and lockout / tagout / blockout / testout energy source according to ANSI standards (see "References").

### ⚠ DANGER

If this equipment will be installed in an enclosed area, test the gas level or dust content before using a cutting torch or welding. Using a torch or welding in an area with gas or dust may cause an explosion resulting in serious injury or death. Follow local confined space procedures.

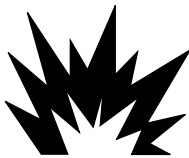

5. If using a cutting torch or welding, test atmosphere for gas level or dust content. Cover conveyor belt with fire retardant cover.

### IMPORTANT

Center the belt cleaner blades to clean an area narrower than the conveyor belt width. This allows for side-to-side movement of the belt and prevents damage to the belt edge.

### NOTE

The chute wall that the tensioner will be located on is referred to as the "operator side." The other side of the chute is referred to as the "far side." (If installing dual tensioners, side that is most accessible is "operator side.")

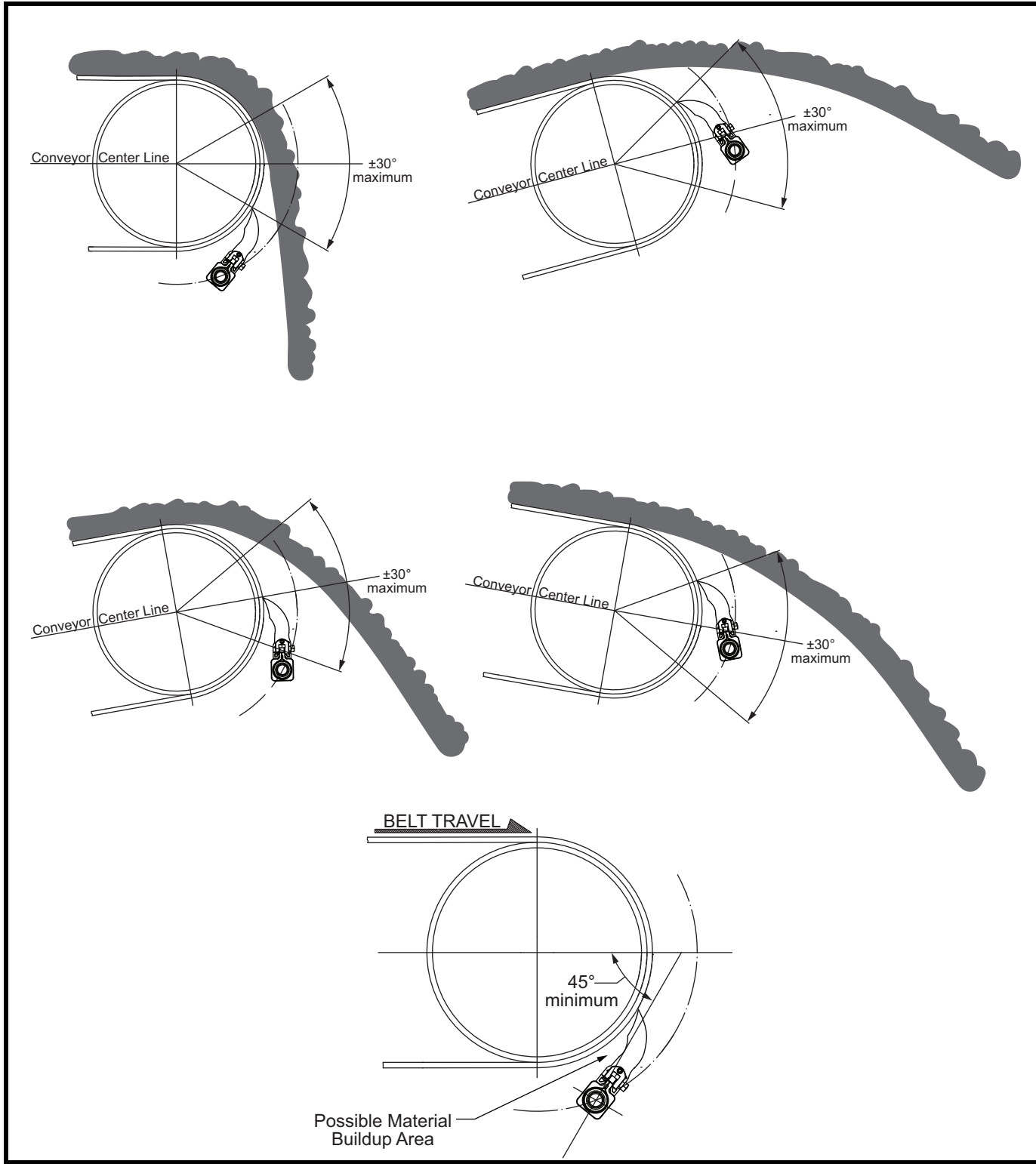
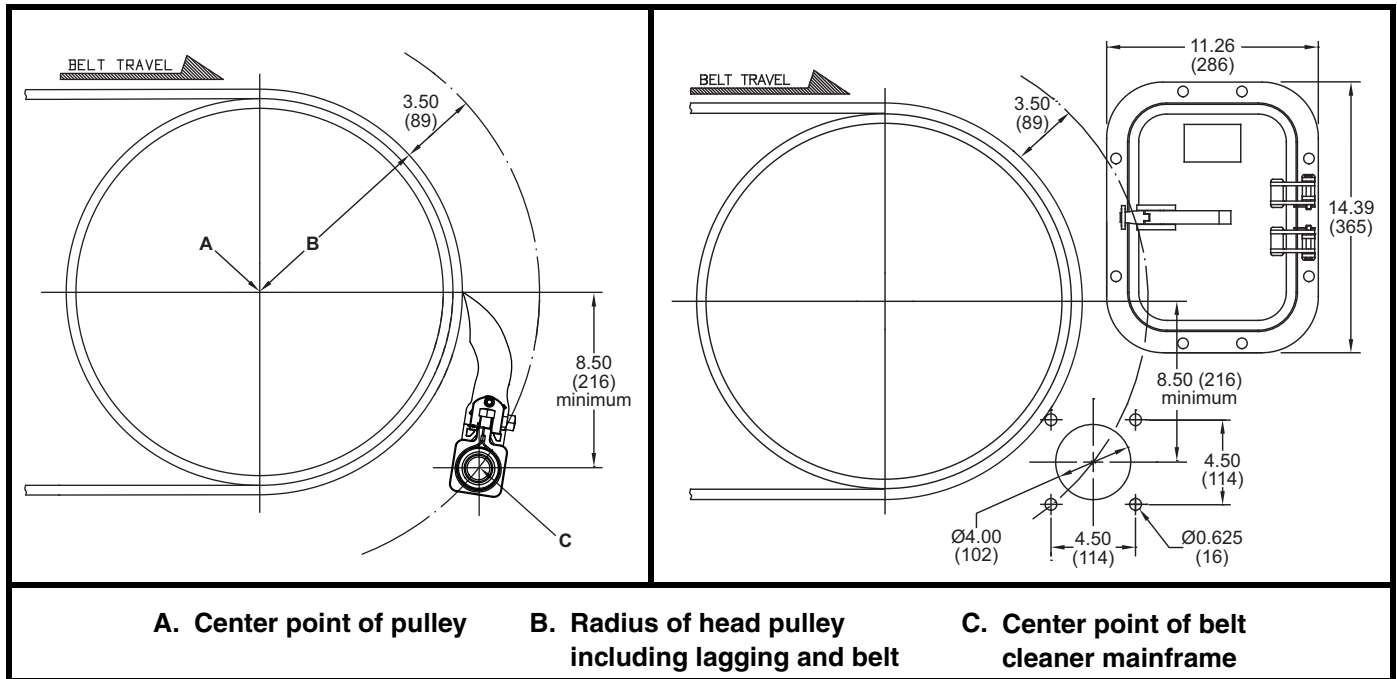

Figure 1. Belt Cleaner Mounting Locations

6. Inspect belt cleaner mounting area for possible obstructions that could interfere with proper mounting. Refer to following guidelines:
  - a. The cleaner can be mounted anywhere on the arc from +30 degrees to -30 degrees from a center line parallel to the belt line as long as:
    - (1) The blade is not in the direct flow of discharging material causing premature blade wear.
    - (2) The diameter of the pulley is big enough that the blade does not trap or hold material between the inside of the blade and the belt.
    - (3) There is at least the equivalent of a 45 degree angle between the blade and belt to prevent material buildup in this space.
  - b. Lack of service is the main cause of poor belt cleaning performance. Follow CEMA guidelines for access:
    - (1) Clearance for service outside the chute must be at least equal to the belt width.
    - (2) Cleaners must have service platforms. CEMA recommends cleaners be mounted at least 24 in. (600 mm) above the work platform.
    - (3) If the belt width is 54 in. (1400 mm) or larger consider access doors on both sides of the chute.
  - c. Refer to “Installing Belt Cleaner and Tensioner” and “Part Numbers” sections of this manual for specific mounting and cleaner dimensions.

# Installing Belt Cleaner and Tensioner



**Figure 2. Belt Cleaner Mainframe Location & Chute Wall Cutouts**

## *Locating belt cleaner mainframe*

1. On operator side of chute, find pulley center point (A).
2. Measure radius of head pulley including lagging and belt thickness (B). To this dimension, add 3.50 in. (89 mm).
3. Starting from center point (A), measure the total distance calculated in step 2 (B + 3.50) and draw an arc on chute wall.
4. Measure down from pulley's horizontal centerline the distance shown in Figure 2 and draw a horizontal line parallel to it. Locate center point of belt cleaner mainframe (C) where this line intersects the arc on the chute wall.
5. Make sure mainframe and blade do not lie in path of material unloading from conveyor belt.
6. Repeat steps 1 through 5 for far side chute wall.
7. Drill or cut holes for tensioner mounting plates on chute walls as follows:
  - a. If bolting tensioner mounting plates to chute walls, do the following:
    - (1) Drill or cut one 4-in. hole for mainframe and four 5/8-in. holes for screws in both operator side and far side chute walls. Remove burrs and sharp edges.
  - b. If welding tensioner mounting plates to chute walls, do the following:
    - (1) Drill or cut one 4-in. hole for mainframe in both operator side and far side chute walls. Remove burrs and sharp edges.
8. If using Martin® Inspection Door, cut access door opening and mounting holes according to *Martin® Inspection Door Operator's Manual*, P/N M3891.

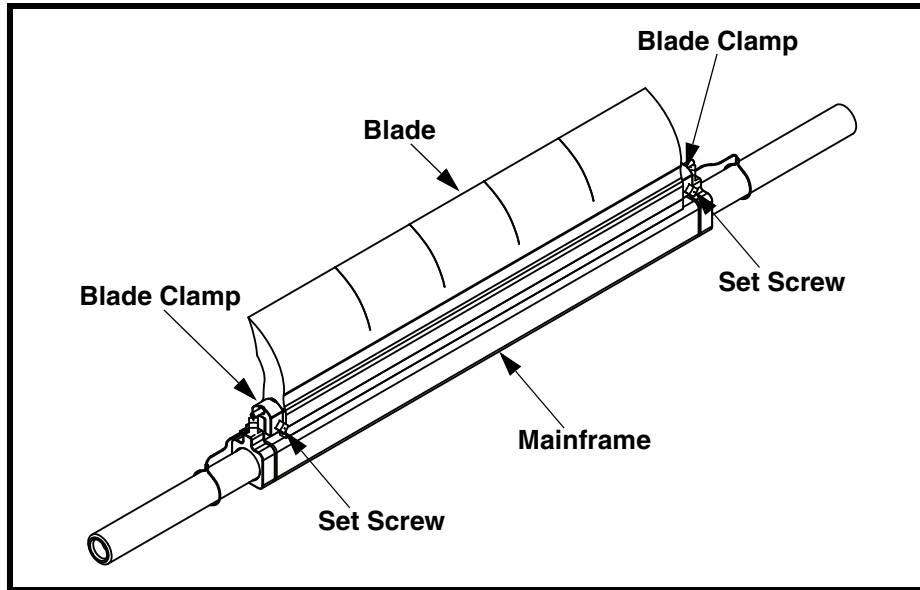

**Figure 3. Removing and Installing Blade**

***Removing blade***

1. Loosen set screw on each blade clamp. Remove blade clamp from blade and mainframe. Make sure blade clamp lanyards remain attached to mainframe.
2. Remove blade from mainframe.

***Installing tensioner***

1. Install tensioner according to applicable tensioner's manual.
2. If using Martin® Inspection Door, install according to *Martin® Inspection Door Operator's Manual*, P/N M3891.

***Installing blade***

1. Position blade on mainframe with blade curve facing conveyor belt.
2. Install blade clamps onto mainframe and insert into blade.
3. Center blade on mainframe and tighten blade clamp set screws.
4. Make sure blades are centered on belt and mainframe is parallel to belt.
5. Tension belt cleaner according to applicable tensioner's manual.

# After Installing Belt Cleaner



1. Thoroughly wipe chute wall clean above tensioner.
2. Place Conveyor Products Warning Label (P/N 23395) on outside chute wall visible to belt cleaner operator.
3. Additional safety labels are available from CEMA. For more information regarding CEMA safety labels visit [www.cemanet.org](http://www.cemanet.org).

## **⚠ WARNING**

Failure to remove tools from installation area and conveyor belt before turning on energy source can cause serious injury to personnel and damage to belt.

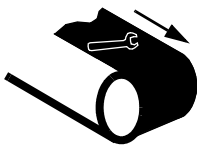

## **⚠ DANGER**

Do not touch or go near conveyor belt or conveyor accessories when conveyor belt is running. Body or clothing can get caught and pull body into conveyor belt, causing severe injury or death.



4. Turn on conveyor belt for 1 hour, then turn off.

## **⚠ DANGER**

Before installing, servicing, or adjusting the belt cleaner, turn off and lockout / tagout / blockout / testout all energy sources to the conveyor and conveyor accessories according to ANSI standards. Failure to do so could result in serious injury or death.

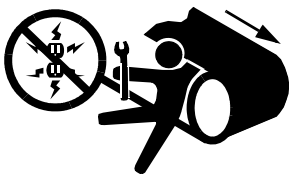

- a. Make sure all fasteners are tight. Tighten if necessary.
- b. Inspect belt cleaner for the following:
  - (1) Wear. (A small amount of “break-in” wear may be found. This will stop once blades wear to conveyor belt contour.)
  - (2) Material buildup. (No material between blades and return side of conveyor belt should be found.)
- c. If wear, material buildup, or some other problem exists, see “Troubleshooting.”

# Weekly Maintenance

---

## IMPORTANT

Read entire section before beginning work.

## NOTE

Maintenance inspection should be performed no less than weekly. Some applications may require more frequent maintenance inspections.



## ⚠ DANGER

Before installing, servicing, or adjusting the belt cleaner, turn off and lockout / tagout / blockout / testout all energy sources to the conveyor and conveyor accessories according to ANSI standards. Failure to do so could result in serious injury or death.

1. Remove any material from belt cleaner.
2. Make sure all fasteners are tight. Tighten if necessary.
3. Check tension on cleaner. Re-tension if necessary.
4. Wipe all labels clean. If labels are not readable, contact Martin Engineering or a representative for replacements.
5. Check blades for excessive wear. Replace if necessary.
6. Remove equipment from service if there is any indication it is not functioning properly. Call Martin Engineering or a representative for assistance. Do NOT return equipment to operation until the cause of the problem has been identified and corrected.

## ⚠ WARNING

Failure to remove tools from maintenance area and conveyor belt before turning on energy source can cause serious injury to personnel and damage to belt.

7. Remove all tools from maintenance area.

## ⚠ DANGER

Do not touch or go near conveyor belt or conveyor accessories when conveyor belt is running. Body or clothing can get caught and pull body into conveyor belt, causing severe injury or death.

8. Start conveyor belt. Observe belt cleaner operation for several revolutions of the belt. Service or adjust belt cleaner as necessary to ensure proper belt cleaner operation.

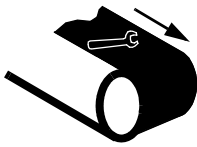

# Troubleshooting

Symptom	Corrective Action
Insufficient cleaning and carryback.	<ul style="list-style-type: none"> <li>• Tension of cleaner on belt is set too low or too high. Increase or decrease tensioner setting.</li> <li>• Blades are worn. Check blades and replace if necessary.</li> </ul>
Blade wears only in the center.	<ul style="list-style-type: none"> <li>• Use a segmented style blade for crown pulleys.</li> <li>• Consider narrowing the blade width to clean the middle of the belt.</li> </ul>
Noise or vibration.	Tension is not sufficient or is set too high. Correct tension as necessary. If this does not correct problem, blade urethane may not match application. Contact Martin Engineering or representative.
High blade wear rate.	Tension of cleaner on belt is set too high. Reduce tensioner setting.
Unusual wear or damage to blades.	Check belt splice(s) and repair as necessary.
Bent or broken mainframe or support frame due to blade slipping through.	If blades are worn to or past the wear line, replace blades. If blades are not worn, check mainframe location.
Corrosion or chemical degradation.	Blade urethane may not match application. Contact Martin Engineering or a representative.

## NOTE

Conveyor equipment such as conveyor belt cleaners are subject to a wide variety of bulk materials characteristics and often have to perform under extreme operating or environmental conditions. It is not possible to predict all circumstances that may require troubleshooting. Contact Martin Engineering or a representative if you are experiencing problems other than those listed in the “Troubleshooting” chart above. Do not return the equipment to operation until the problem has been identified and corrected.

### ***Installation checklist***

If after taking the corrective actions suggested under “Troubleshooting” you are still experiencing problems, check for the following:

Installation Checklist
✓ Pre-Cleaner mainframe is proper distance from belt surface on both ends of mainframe and parallel to the pulley shaft.
✓ Pre-Cleaner blade tip does not lie in path of material flow.
✓ Blades are centered on belt.

# Part Numbers

This section provides product names and corresponding part numbers for Martin® QC1+™ Cleaner HD and related equipment. Please reference part numbers when ordering parts:

**Martin® QC1+™ Cleaner HD**

**Martin® QC1+™ Cleaner HD Mainframe Assembly:**  
P/N C1QCHSXXSXXPX. See Figure 4.

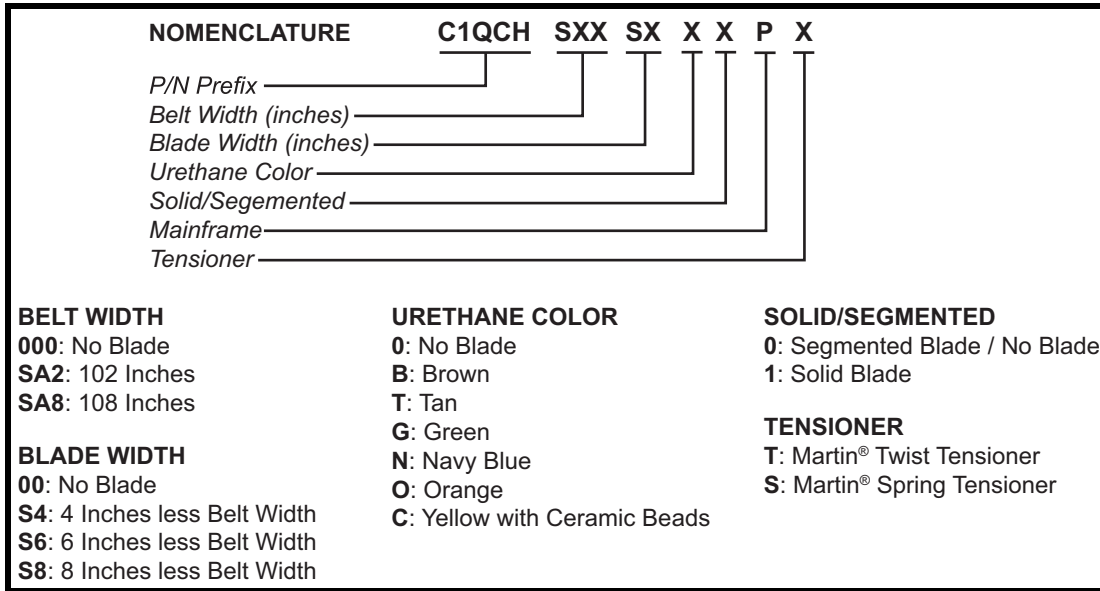

## Recommended Tensioners

Belts 18 to 48 in. wide:

**Martin® Twist Tensioner:** P/N 38850.

**Martin® Twist Tensioner with “L” Bracket:** P/N 38850-L.

**Martin® Spring Tensioner:** P/N 38180

Belts 54 to 96 in. wide:

**Dual Martin® Twist Tensioners:** P/N 38850-2.

**Dual Martin® Twist Tensioners with “L” Bracket:** P/N 38850-2L.

**Dual Martin® Spring Tensioners:** P/N 38180-2

## Operator’s manuals

**Martin® Spring and Air Tensioners Operator’s Manual:** P/N M3263.

**Martin® Twist Tensioner Operator’s Manual:** P/N M3837.

**Martin® Inspection Door Operator’s Manual:** P/N M3891.

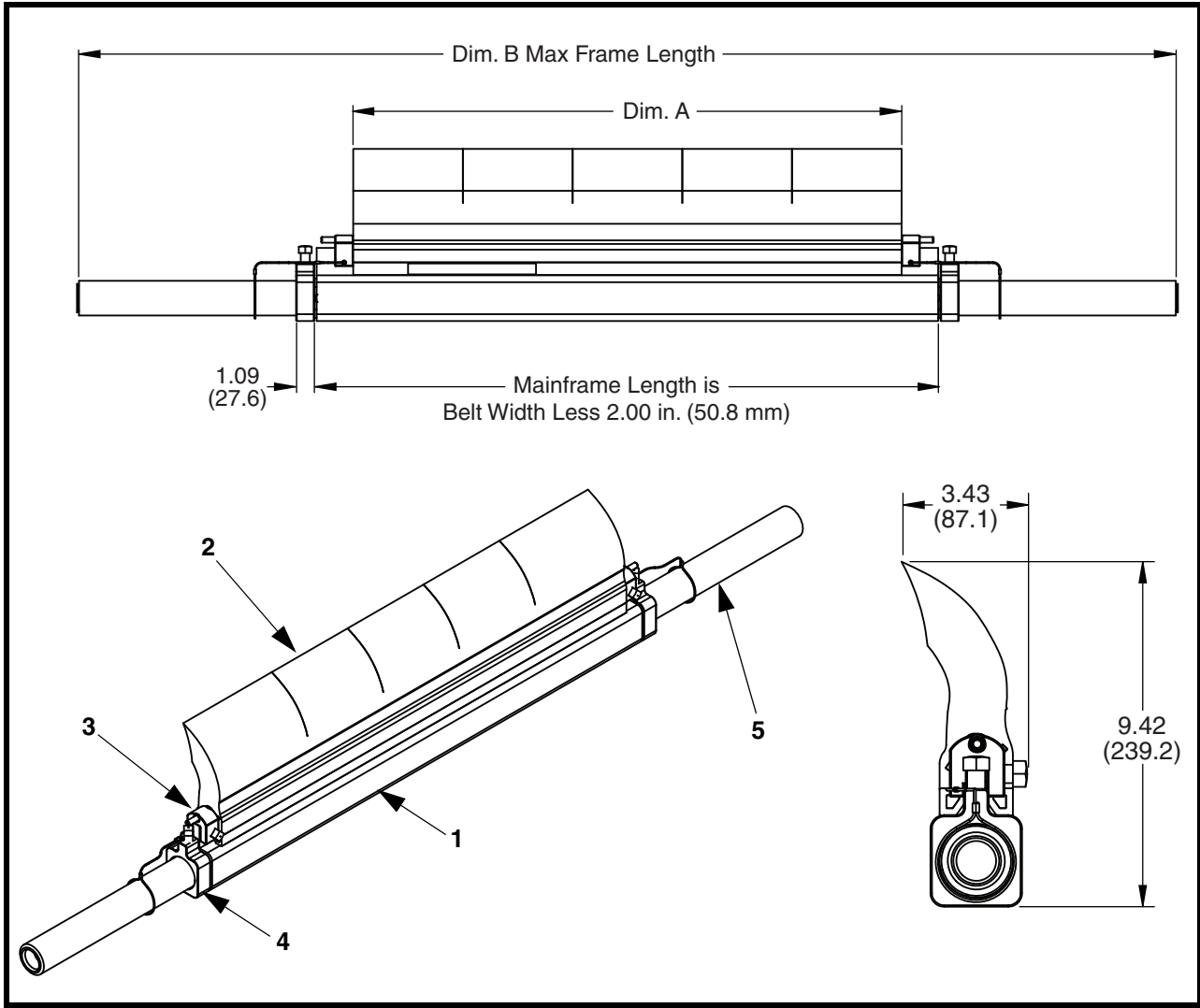

Figure 4. Martin® QC1+™ Cleaner HD Assembly, P/N C1QCHSXXXSXXXPX

Item	Description	Part No.	Qty.
1	Mainframe Weldment	Table III	1
2	Blade	Table III	2
3	Blade Clamp	C1QCA1002ST	2
4	Collar with Set Screw	C1QCA1001ST	2
5	Torque Tube	Table III	2
6 (NS)	Label Martin® Products	38048	2
7 (NS)	Label Conveyor Products Warning	23395	2
8 (NS)	Manual Operator's	M4124	1
9 (NS)	Martin® Twist Tensioner Assembly	38850/38850-2	1
	Martin® Spring Tensioner Assembly	38180/38180-2	1

NS = Not Shown

**Table III. Part Numbers and Dimensions for Martin® QC1+™ Cleaner HD Assembly**

Standard Blade Assy. Part No.	Dim. A in. (mm)	Dim. B in. (mm)	Item No. 1	Item No. 2	Item No. 5	Weight (lbs.) w/o Tensioner
C1QCHS18S4XXPX	14 (356)	34 (864)	C1QCHMS16P	C1QCHBS14XX	C1QATTS16	35.3
C1QCHS18S6XXPX	12 (305)			C1QCHBS12XX		34.2
C1QCHS18S8XXPX	10 (254)			C1QCHBS10XX		33.1
C1QCHS24S4XXPX	20 (508)	46 (1168)	C1QCHMS22P	C1QCHBS20XX	C1QATTS19	45.0
C1QCHS24S6XXPX	18 (457)			C1QCHBS18XX		43.9
C1QCHS24S8XXPX	16 (406)			C1QCHBS16XX		42.8
C1QCHS30S4XXPX	26 (660)	52 (1321)	C1QCHMS28P	C1QCHBS26XX	C1QATTS19	52.2
C1QCHS30S6XXPX	24 (610)			C1QCHBS24XX		51.1
C1QCHS30S8XXPX	22 (559)			C1QCHBS22XX		50.0
C1QCHS36S4XXPX	32 (813)	60 (1524)	C1QCHMS34P	C1QCHBS32XX	C1QATTS24	63.5
C1QCHS36S6XXPX	30 (762)			C1QCHBS30XX		62.4
C1QCHS36S8XXPX	28 (711)			C1QCHBS28XX		61.3
C1QCHS42S4XXPX	38 (965)	72 (1829)	C1QCHMS40P	C1QCHBS38XX	C1QATTS24	70.8
C1QCHS42S6XXPX	36 (914)			C1QCHBS36XX		69.7
C1QCHS42S8XXPX	34 (864)			C1QCHBS34XX		68.6
C1QCHS48S4XXPX	44 (1118)	78 (1981)	C1QCHMS46P	C1QCHBS44XX	C1QATTS24	78.0
C1QCHS48S6XXPX	42 (1067)			C1QCHBS42XX		76.9
C1QCHS48S8XXPX	40 (1016)			C1QCHBS40XX		75.8
C1QCHS54S4XXPX	50 (1270)	84 (2134)	C1QCHMS52P	C1QCHBS50XX	C1QATTS24	85.3
C1QCHS54S6XXPX	48 (1219)			C1QCHBS48XX		84.2
C1QCHS54S8XXPX	46 (1168)			C1QCHBS46XX		83.1
C1QCHS60S4XXPX	56 (1422)	90 (2286)	C1QCHMS58P	C1QCHBS56XX	C1QATTS30	97.4
C1QCHS60S6XXPX	54 (1372)			C1QCHBS54XX		96.3
C1QCHS60S8XXPX	52 (1321)			C1QCHBS52XX		95.2
C1QCHS66S4XXPX	62 (1575)	96 (2438)	C1QCHMS64P	C1QCHBS62XX	C1QATTS30	104.5
C1QCHS66S6XXPX	60 (1524)			C1QCHBS60XX		103.6
C1QCHS66S8XXPX	58 (1473)			C1QCHBS58XX		102.5
C1QCHS72S4XXPX	68 (1727)	102 (2591)	C1QCHMS70P	C1QCHBS68XX	C1QATTS30	111.8
C1QCHS72S6XXPX	66 (1676)			C1QCHBS66XX		110.7
C1QCHS72S8XXPX	64 (1626)			C1QCHBS64XX		109.8

Standard Blade Assy. Part No.	Dim. A in. (mm)	Dim. B in. (mm)	Item No. 1	Item No. 2	Item No. 5	Weight (lbs.) w/o Tensioner
C1QCHS78S4XXPX	74 (1880)	108 (2743)	C1QCHMS76P	C1QCHBS74XX	C1QATTS42	128.7
C1QCHS78S6XXPX	72 (1829)			C1QCHBS72XX		127.6
C1QCHS78S8XXPX	70 (1778)			C1QCHBS70XX		126.8
C1QCHS84S4XXPX	80 (2032)	114 (2896)	C1QCHMS82P	C1QCHBS80XX		136.0
C1QCHS84S6XXPX	78 (1981)			C1QCHBS78XX		134.9
C1QCHS84S8XXPX	76 (1930)			C1QCHBS76XX		133.8
C1QCHS90S4XXPX	86 (2184)	120 (3048)	C1QCHMS88P	C1QCHBS86XX		143.3
C1QCHS90S6XXPX	84 (2134)			C1QCHBS84XX		142.2
C1QCHS90S8XXPX	82 (2083)			C1QCHBS82XX		141.1
C1QCHS96S4XXPX	92 (2337)	126 (3200)	C1QCHMS94P	C1QCHBS92XX		150.6
C1QCHS96S6XXPX	90 (2286)			C1QCHBS90XX		149.5
C1QCHS96S8XXPX	88 (2235)			C1QCHBS88XX		148.4
C1QCHSA2S4XXPX	98 (2489)	132 (3353)	C1QCHMSA0P	C1QCHBS98XX		157.9
C1QCHSA2S6XXPX	96 (2438)			C1QCHBS96XX		156.7
C1QCHSA2S8XXPX	94 (2388)			C1QCHBS94XX		155.6
C1QCHSA82S4XXPX	104 (2642)	138 (3505)	C1QCHMSA6P	C1QCHBSA4XX		165.1
C1QCHSA8S6XXPX	102 (2591)			C1QCHBSA2XX		164.0
C1QCHSA8S8XXPX	100 (2540)			C1QCHBSA0XX		162.9

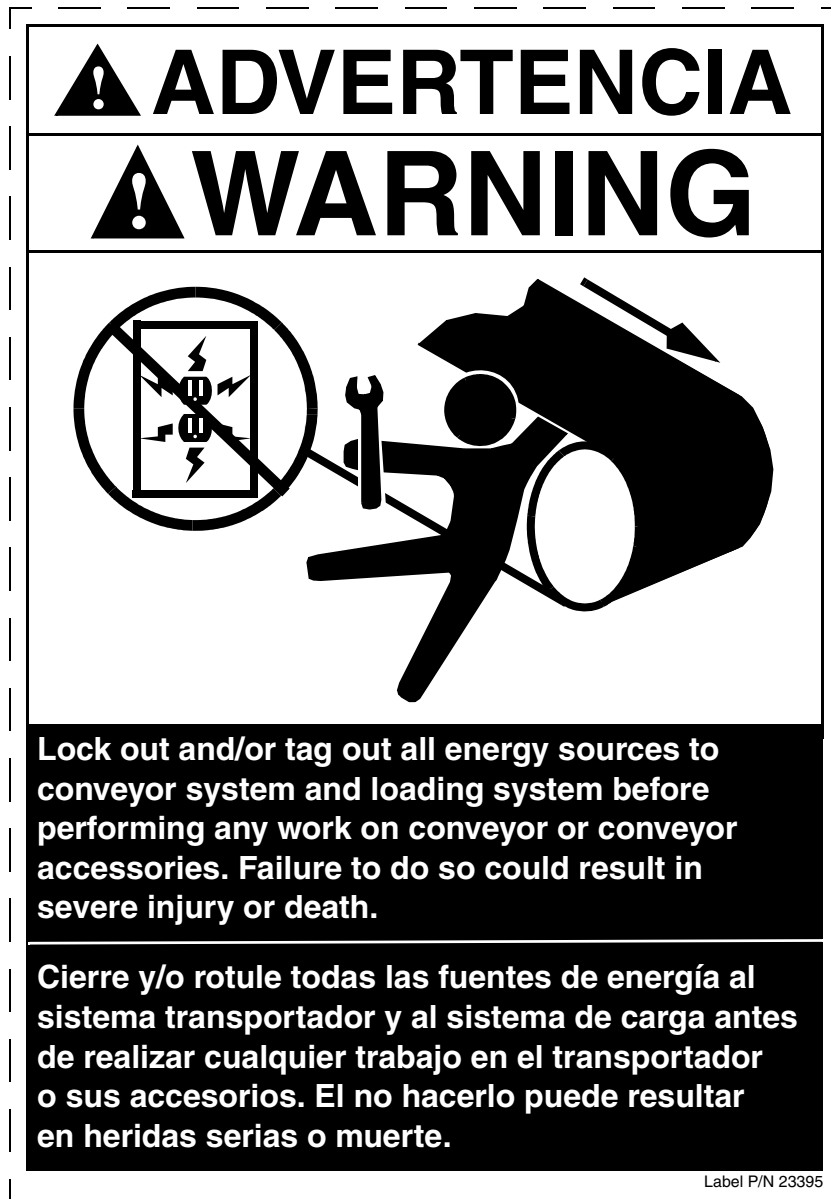
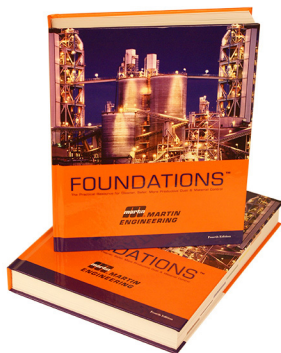

Figure 5. Martin® Conveyor Products Warning Label, P/N 23395

*Any product, process, or technology described here may be the subject of intellectual property rights reserved by Martin Engineering Company. Trademarks or service marks designated with the ® symbol are registered with the U.S. Patent and Trademark Office and may be proprietary in one or more countries or regions. Other trademarks and service marks belonging to Martin Engineering Company in the United States and/or other countries or regions may be designated with the “TM” and “SM” symbols. Brands, trademarks, and names of other parties, who may or may not be affiliated with, connected to, or endorsed by Martin Engineering Company, are identified wherever possible. Additional information regarding Martin Engineering Company’s intellectual property can be obtained at [www.martin-eng.com/trademarks](http://www.martin-eng.com/trademarks).*

# Problem Solved™ GUARANTEED!



*For nearly 20 years, Martin Engineering's Foundations™ Books have taught industry personnel to operate and maintain clean and safe belt conveyors. The Foundations™ Book, fourth edition, focuses on improving belt conveyors by controlling fugitive material. "The Practical Resource for Total Dust and Material Control," is a 576-page hard cover volume that provides information of value to industries where the efficient handling of bulk materials is a key to productivity and profitability.*

*Expanding upon the book, our Foundations™ Training Program addresses the design and development of more productive belt conveyors, and is offered in three customizable seminars. Attendees gain a better understanding of conveyor safety and performance, helping to justify upgrade investments and increase profitability.*



## **Martin Engineering USA**

One Martin Place  
Neponset, IL 61345-9766 USA  
800 544 2947 or 309 852 2384  
Fax 800 814 1553  
[www.martin-eng.com](http://www.martin-eng.com)

**COMPANY WITH  
QUALITY SYSTEM  
CERTIFIED BY DNV  
= ISO 9001:2008 =**